

Watkins Wellness®

INSTALLATION

Of your ProLift® II

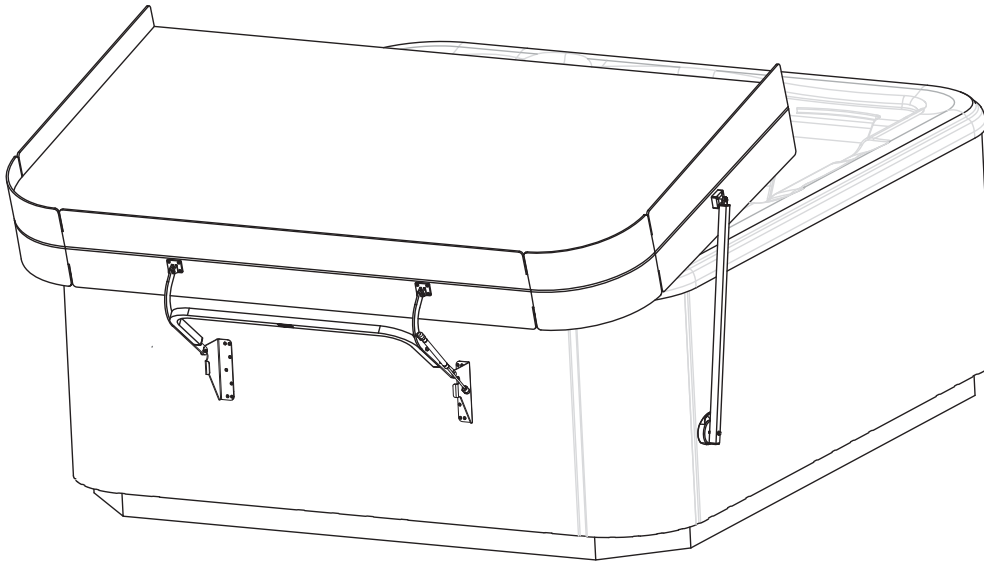

TABLE OF CONTENTS

INSTALLATION REQUIREMENTS..... 1	
KIT INCLUDES	
INSTALLATION REQUIREMENTS..... 2	
TOOLS REQUIRED	
IMPORTANT INFORMATION	
PROLIFT II INSTALLATION PREPARATION. 3	
INSTALL PREPARATION	
LOCATE PLATES	
PROLIFT II INSTALLATION..... 4	
ATTACH BACK HINGES	
ATTACH SIDE HINGES	
ASSEMBLE CROSSLINK	
PROLIFT II INSTALLATION..... 5	
	ATTACH CROSSLINK ASSY.
	PROLIFT II INSTALLATION..... 7
	ATTACH SIDE ARM ASSY.
	ALIGN SIDE ARM ASSY.
	PROLIFT II INSTALLATION..... 9
	INSTALL GAS SPRING
	PROLIFT II INSTALLATION..... 10
	PROLIFT II SPACERS

INTENDED USE IN KIT # 74033

INSTALLATION REQUIREMENTS



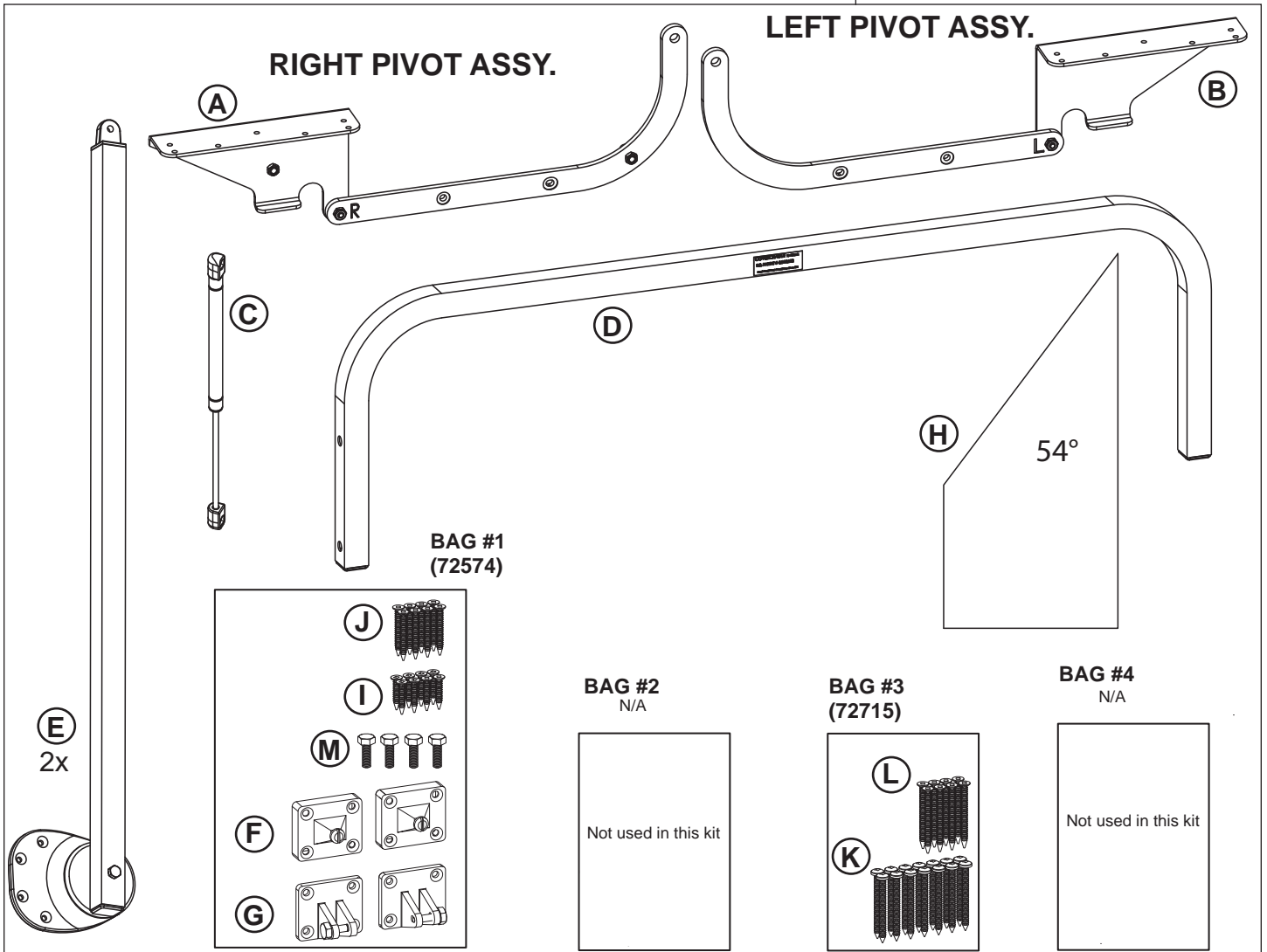



KIT INCLUDES



PART	QUANTITY	DESCRIPTION	PART	QUANTITY	DESCRIPTION
A	1	Pivot Assembly, Right	I	8	#10 x 1" Square Flat Head (Bag 1)
B	1	Pivot Assembly, Left	J	8	#10 X 1½" Square Flat Head (Bag 1)
C	1	Gas Spring	K	14	#10 X 2" Square Pan Head (Bag 3)
D	1	Crosslink Assembly	L	8	#10 X 2" Square Flat Head (Bag 3)
E	1	Side Arm Assembly	M	4	¼-20 x ¾" Hex Bolt (Bag 1)
F	2	Side Hinge with Screw			
G	2	Back Hinge with Screw			
H	1	Template 54°			

INSTALLATION REQUIREMENTS

TOOLS REQUIRED

<p>Cordless Drill</p> 	<p>Flat Head Screwdriver</p> 	<p>7/16" Socket with Ratchet</p> 	<p>#2 Square Drive Bit</p> 
<p>1/8" Drill Bit (3.175mm)</p> 	<p>Fine Tip Marker</p> 	<p>Safety Glasses</p> 	

IMPORTANT INFORMATION

- **One Technician is recommended for this installation.**
- Read all of the instructions thoroughly before performing this installation.
- There must be a minimum of 30" clearance between the wall and the retracting side of the spa for cover to operate properly and 4" on each side for Side Arm clearance.
- The Warning Label on the cover is always on the front of the cover; the lifter will attach on either the back side of the spa or the left side of spa depending on cover configuration.
- The cover side with the Warning Label will always fold over to the side without the Warning Label.
- To ensure that the cover seals correctly, the spa must be level.
- Use screws in bag #3 on spas with removable panels.

PROLIFT II INSTALLATION PREPARATION

STEP 1 INSTALL PREPARATION

- Refer to (Figure 1.1) for the Left and Right cover lifter set orientation for (Front to Back) cover configuration:
 - On a (Front to Back) cover configuration, the Left and Right cover lifter set will attach on back side of spa (Figure 1.1).
 - The cover will fold toward the back side of spa.
- Refer to (Figure 1.2) for the Left and Right cover lifter set orientation for (Side to Side) cover configuration:
 - On a (Side to Side) cover configuration, the Left and Right cover lifter set will attach on left side of spa (Figure 1.2).
 - The cover will fold toward the left side of spa.
- Align the cover:
 - Position the cover evenly on all spa sides See (Figure 1.3).

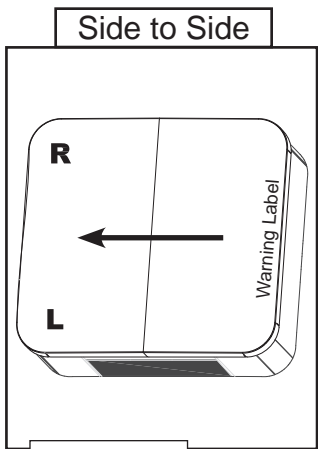

Figure 1.2

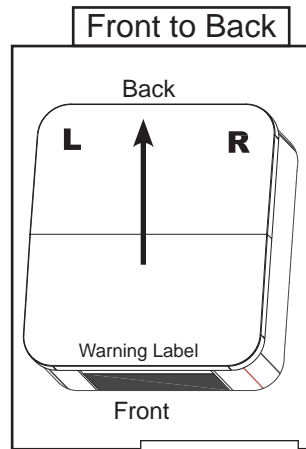

Figure 1.1



Figure 1.3

NOTE

The cover warning label must be facing the front of the spa on (Front to Back) configuration or the right side of spa on (Side to Side) configuration (Figure 1.1 and 1.2)

STEP 2 LOCATE PLATES

Every Watkins cover has 6 aluminum plates installed into the foam core hidden beneath the vinyl on 3 sides of the cover. There are two plates on the opposite side of the Warning Label and two on each side of the cover (Figure 1.4).

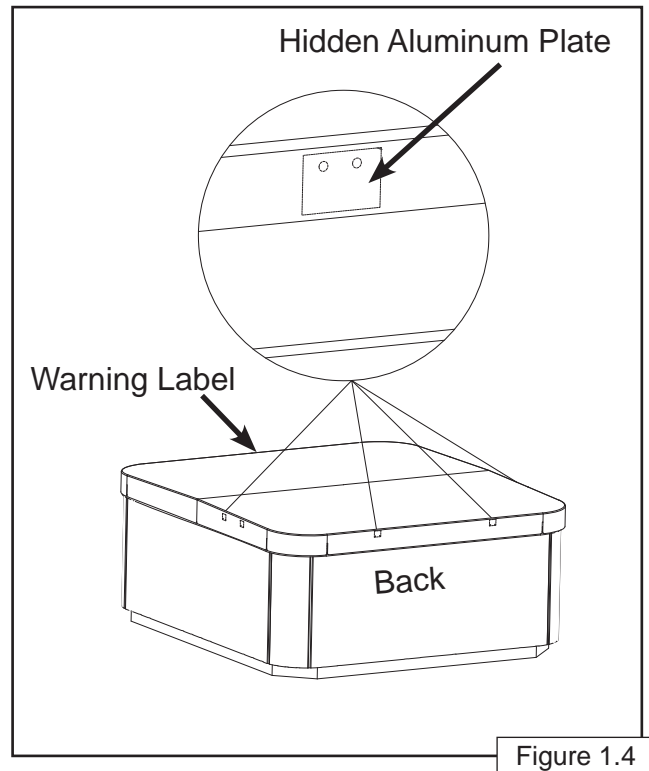

Figure 1.4

Only the hidden aluminum plate closest to the middle of the cover on each side is used for this cover lifter as well as the two plates in the back opposite the Warning Label. There are two predrilled holes on the top of each plate. Feel around the side of the cover to find the holes in the plates. Use a fine tip marker to mark the center of the hole for each of the four plates that will be used (Figure 1.4).

PROLIFT II INSTALLATION

STEP 1 ATTACH BACK HINGES

1. Locate Bag #1. Some of the contents will be used to fasten the Rear Hinges.

REAR HINGES:

2. Line up the top Rear Hinge (G) holes (Figure 2.1) with two of the marked holes on the back side of the cover. Using the cordless drill and square drive bit to fasten the Rear Hinge to the cover by using two of the #10 x 1"square (I) Flat Head screws on the top (marked) holes first. Using the 1/8"(3mm) drill bit and the bottom two holes of the Rear Hinge, drill through the hidden aluminum plate followed by inserting two more of the same screws in the bottom holes. Repeat procedure for second Rear Hinge.

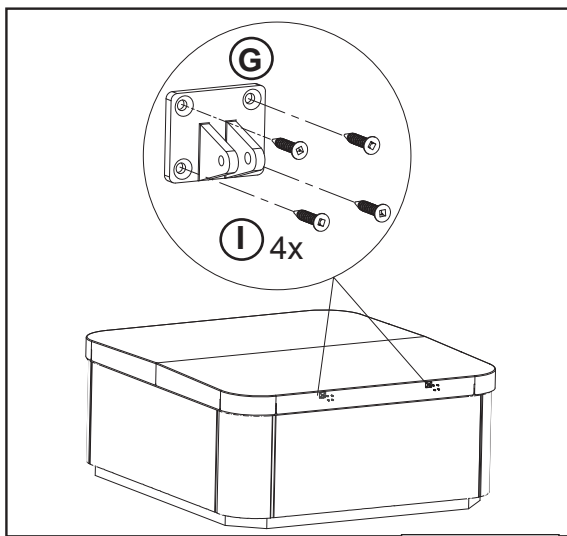

Figure 2.1

STEP 2 ATTACH SIDE HINGES

1. Locate Bag #1. Some of the contents will be used to fasten the Side Hinges.

SIDE HINGES:

2. Line up the top Side Hinge (F) holes (Figure 3.1) with two of the marked holes on one side of the cover.
3. Using the cordless drill and square drive bit, fasten the Side Hinge to the cover by using

two of the #10 x 1½"square (J) Flat Head screws on the top (marked) holes first.

4. Using the 1/8"(3mm) drill bit and the bottom two holes of the Side Hinge, drill through the hidden aluminum plate followed by inserting two more of the same screws in the bottom holes (Figure 3.1).

Repeat procedure for Side Hinge on opposite side of the cover.

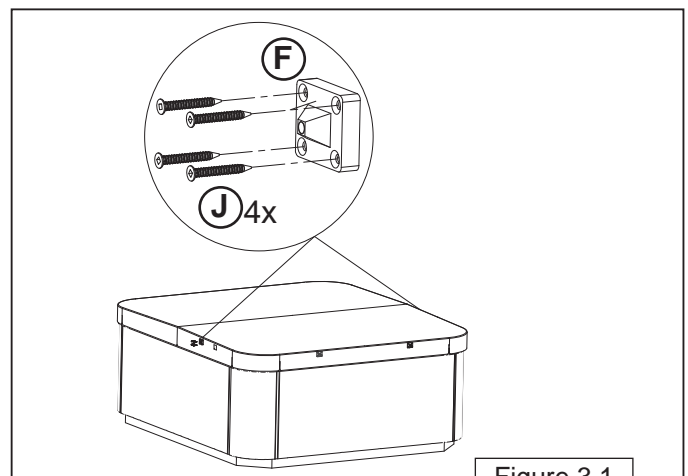

Figure 3.1

STEP 3 ASSEMBLE CROSSLINK

1. Locate the Right & Left Pivot Assemblies, Crosslink, and (4) ¼"-20 Hex Bolts (Figure 4.1).

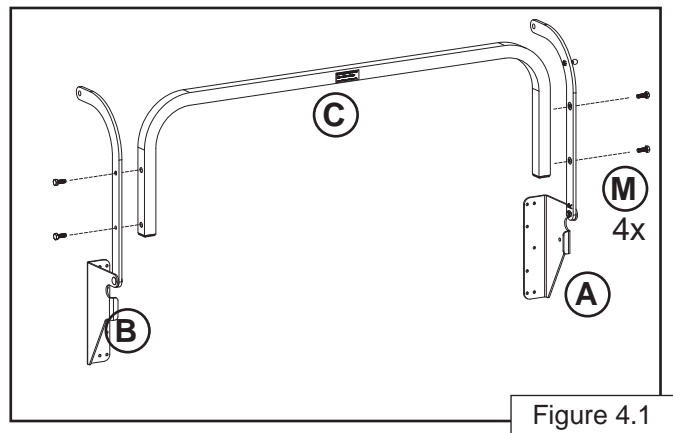

Figure 4.1

2. Orient (Figure 4.1) on floor and attach (A and B to C using (4) ¼"-20 Hex Bolts (M).

PROLIFT II INSTALLATION

STEP 4 ATTACH CROSSLINK ASSY.

1. Unscrew Pan Head Screws attached to the Rear Hinges (G) (Figure 5.1).

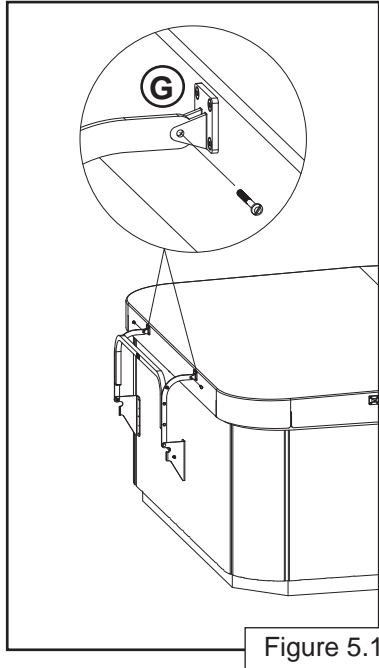

Figure 5.1

2. Align both Pivot Assemblies (attached to the Crosslink assembly) inside the Rear Hinges and fasten using the two Pan Head Screws (Figure 5.1).

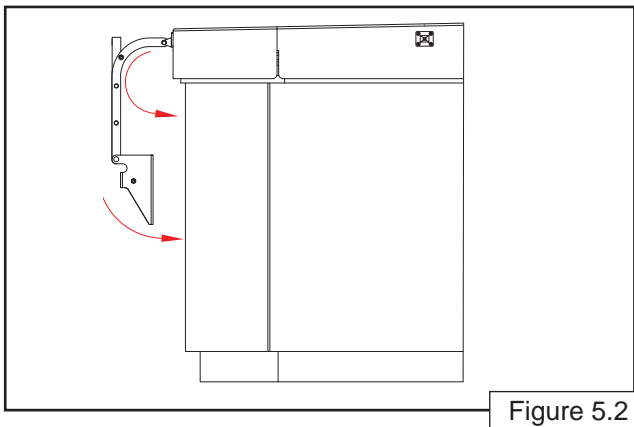

Figure 5.2

3. Rotate Pivot Assemblies until the bottom (Mounting Bracket) touches the side of the spa (Figure 5.2).

For the following steps on Utopia® Spas (2016-Current), please go to page 10 at the end of this document.

IMPORTANT: Carefully examine cover to be sure it is still aligned evenly with the outside edges of the spa bar top (Figure 1.3).

4. Using the Mounting Bracket (bottom part of the Pivot Assembly) as a template, predrill 1/8"(3mm) holes into the back of the spa (Figure 4.3) with 1/2"(12.5mm) max. depth. There are (7) holes per Mounting Bracket (Figure 5.3).

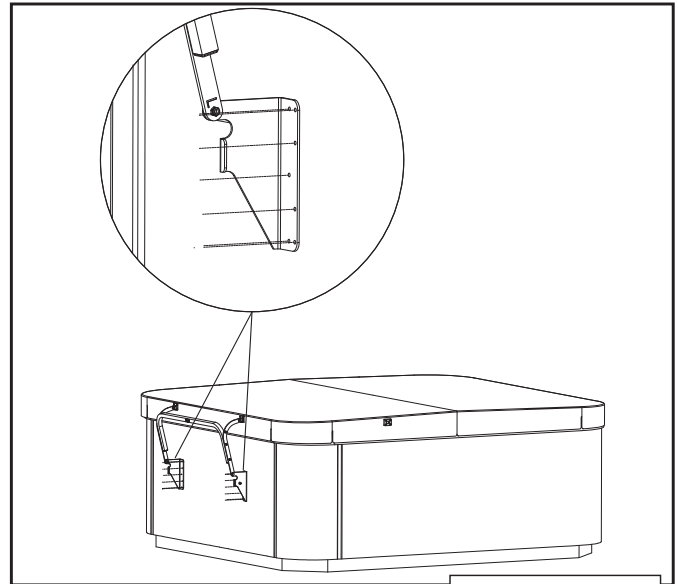

Figure 5.3

NOTE

Use the appropriate size screws to secure the Mounting Brackets. Please use (Figure 5.4) and information on **Page 6** of this document to determine the correct screw size.

PROLIFT II INSTALLATION

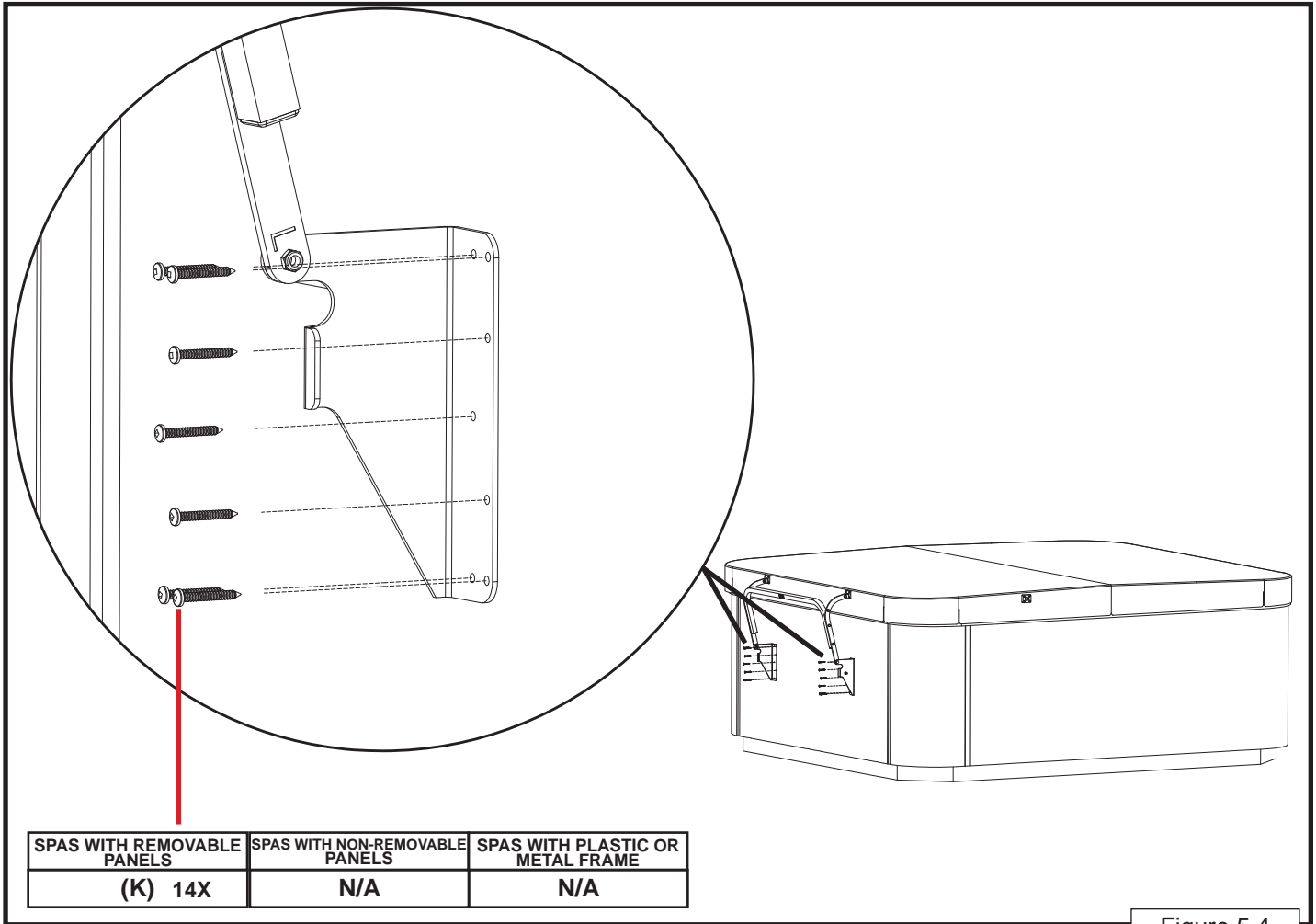

Figure 5.4

a. Spas with Removable Panels	b. Spas with Non-removable Panels	c. Spas with Plastic or Metal Frame
<p>5a. Secure the Mounting Brackets to the spa cabinet using (14) of the Pan Head Screws (Figure 5.4). You will be using the following bag: Bag #3 (K) (#10 2" screws) used on removable panel spas.</p>	<p>Not compatible.</p>	<p>Not compatible.</p>

NOTE See Page 2 for important information on screw size compatibility.

PROLIFT II INSTALLATION

STEP 5 ATTACH SIDE ARM ASSY

1. Remove the single bolt attached to the Side Hinge (F) (Figure 6.1) on the side of the spa. Attach the Side Arm Assembly (E) (Figure 6.1) to the Side Hinge (F) (Figure 6.1) using the single bolt. Repeat on other side of spa.
2. **IMPORTANT:** Plastic Bottom (Pivot Bracket) of Side Arm Assembly (E) must lay flat against spa cabinet.

DO NOT OVERTIGHTEN SCREW or the cover will bind.

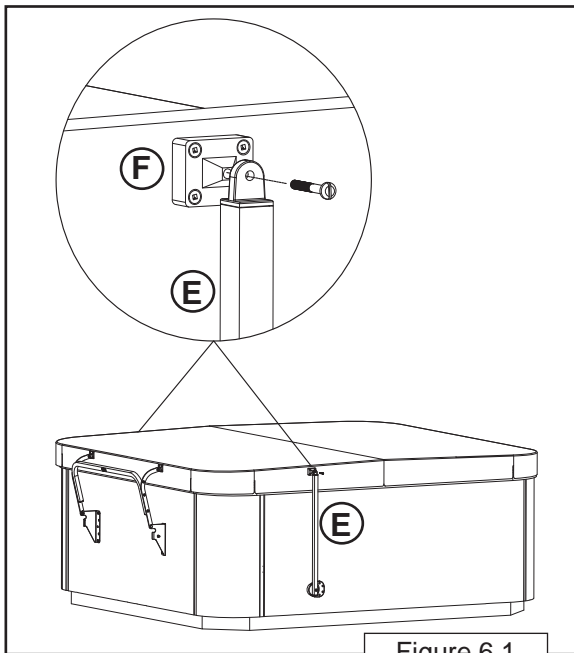

Figure 6.1

STEP 6 ALIGN SIDE ARM ASSY.

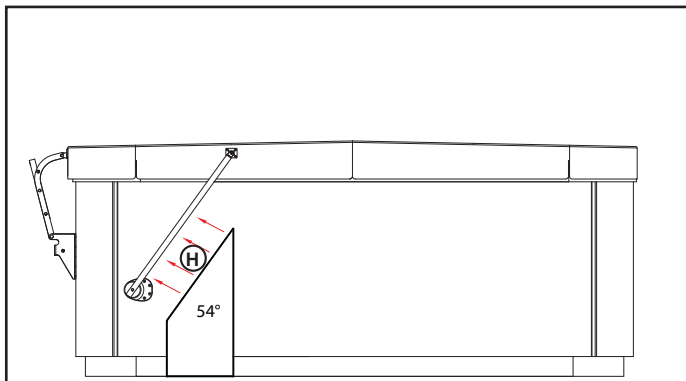

Figure 7.1

1. Locate the Cardboard Template (H) and place on ground below Side Arm Assembly (Figure 7.1).
2. Slide Template against Side Arm Assembly, making sure the entire angle of the Template touches the Side Arm Assembly (Figure 7.1).
3. Position the Plastic Bottom (Pivot Bracket) with the holes facing away from the back of the cover (Figure 7.2).

NOTE

If Pivot Bracket rests on both the side panel and corner panel, creating a gap behind the Pivot Bracket, Pivot Bracket may be rotated 180° and placed onto the corner panel of spas.

4. Holding Pivot Bracket in place, mark all 4 holes and pre-drill with 1/8"(3mm) drill bit at a depth of 1/2"(12.5mm) into spa cabinet.

NOTE

Use the appropriate size screws to secure the Side Arm Assembly. Please use (Figure 7.2) and information on **Page 8** of this document to determine the correct screw size.

PROLIFT II INSTALLATION

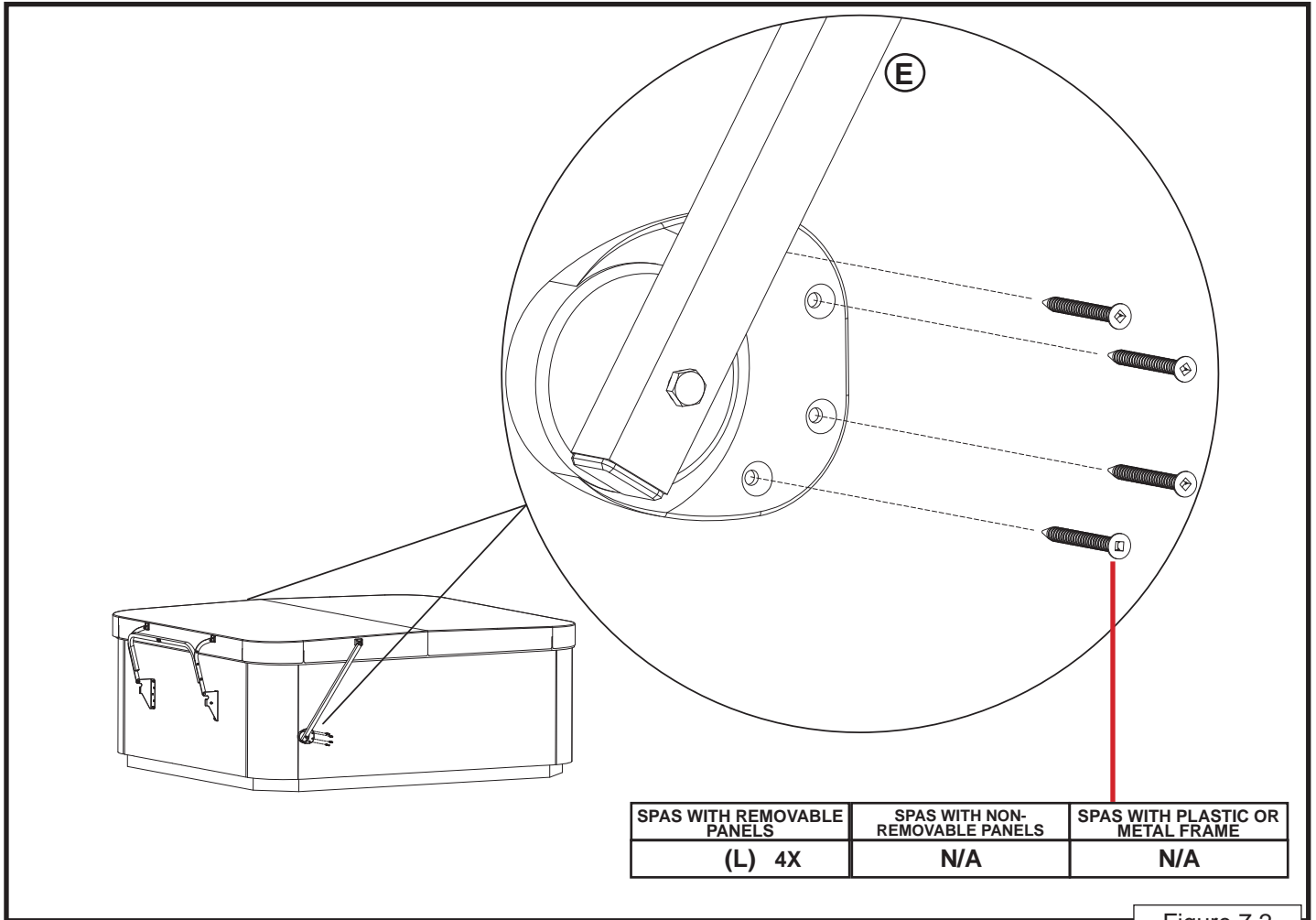

Figure 7.2

a. Spas with Removable Panels	b. Spas with Non-removable Panels	c. Spas with Plastic or Metal Frame
<p>5a. Secure the Side Arm Assembly (E) to the spa cabinet using (4) of the Flat Head Screws per Side Arm Assembly (Figure 7.2). You will be using the following bags: Bag # 3 (L) (#10 2" screws) used on removable panel spas.</p> <p>REPEAT ALIGNMENT ON OTHER SIDE - Make sure both Side Arms angle toward the back of cover.</p> <p>NOTE See Page 2 for important information on screw size compatibility.</p>	<p>Not Compatible.</p>	<p>Not compatible.</p>

PROLIFT II INSTALLATION

STEP 7 INSTALL GAS SPRING

1. Locate the Gas Spring (C) and snap onto the upper ball stud (attached to the Pivot Arm Assembly) with the barrel end of the Gas Spring up (Figure 8.1).

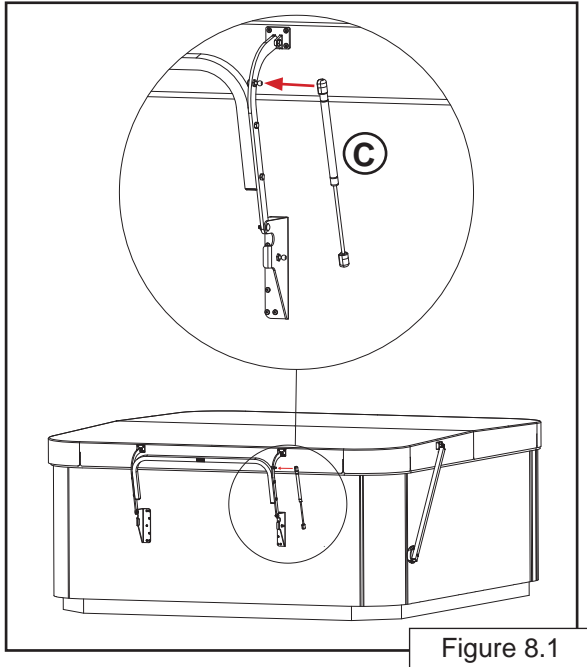

Figure 8.1

2. Fold cover in half and pull to position shown (Figure 8.2). Snap the lower joint of the Gas Spring onto the lower ball stud (Figure 8.2).

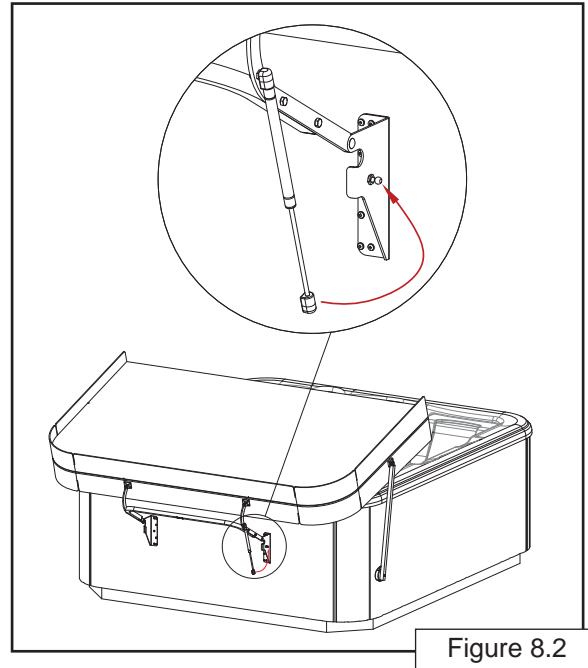

Figure 8.2

PROPER TECHNIQUE FOR OPENING AND CLOSING COVER

3. Push on either side of cover to open or push on either side of cover to close (Figure 8.3). Cover should come to a gentle rest with a slight tilt towards the spa.

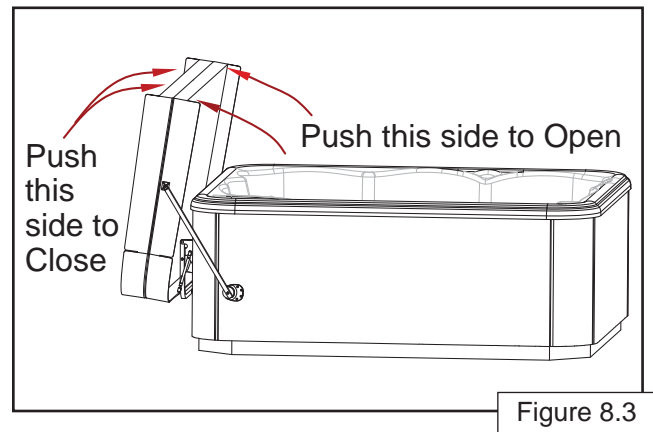

Figure 8.3

NOTE

Always “ease” the cover to the Open and Close Position to avoid “Slamming” thereby prolonging the service life of your cover.

Watkins Wellness®

INSTALLATION

Of the **ProLift® II Spacers** UTOPIA® SPAS ONLY (2016-CURRENT)

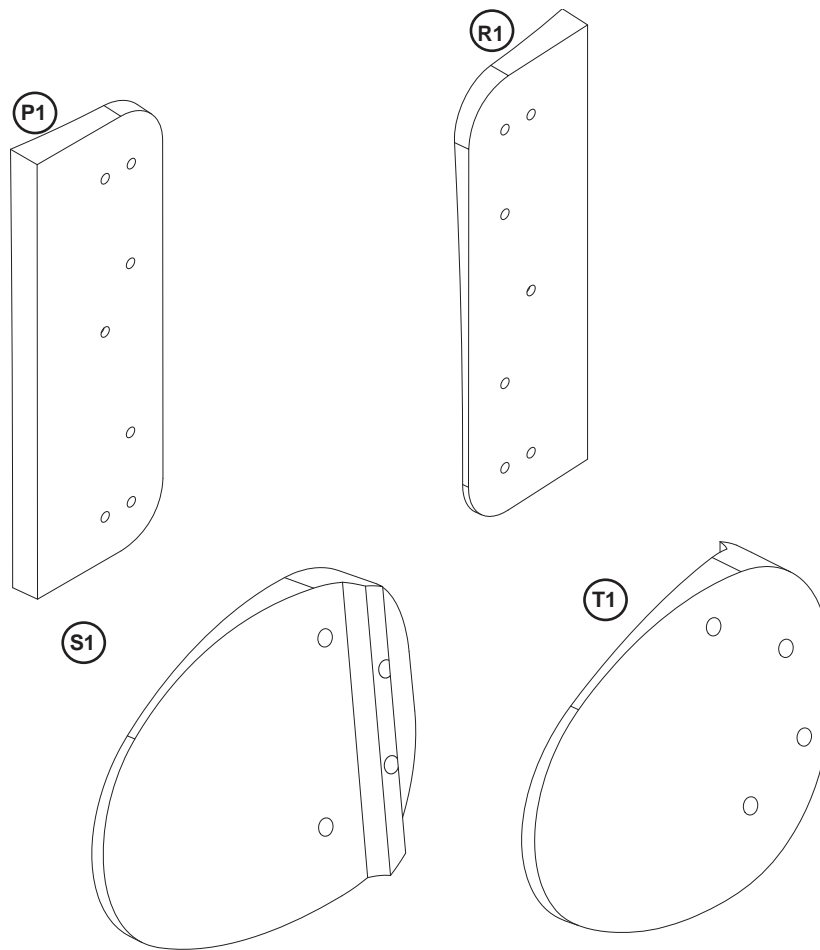

PART	QUANTITY	DESCRIPTION
P1	1	Top Mounting Bracket Spacer, Left
R1	1	Top Mounting Bracket Spacer, Right
S1	1	Side Pivot Bracket Spacer, Left
T1	1	Side Pivot Bracket Spacer, Right

(INTENDED USE KITS: 77699, 77702, 78033)

MOUNTING BRACKET SPACER INSTALLATION

STEP 1

ALIGN MOUNTING BRACKET WITH SPA

1. Rotate Pivot Assemblies until the bottom (Mounting Bracket) touches the side of the spa (Figure 1.1).

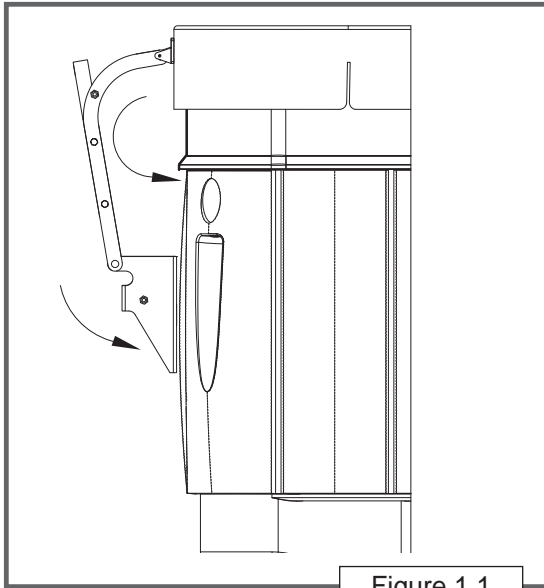

STEP 2

DRILL HOLES INTO SPA

1. Using the Mounting Bracket (bottom part of the Pivot Assembly) as a template, predrill 7/64" holes into spa (Figure 2.1) with 1" max. depth. There are (7) holes per Mounting Bracket.

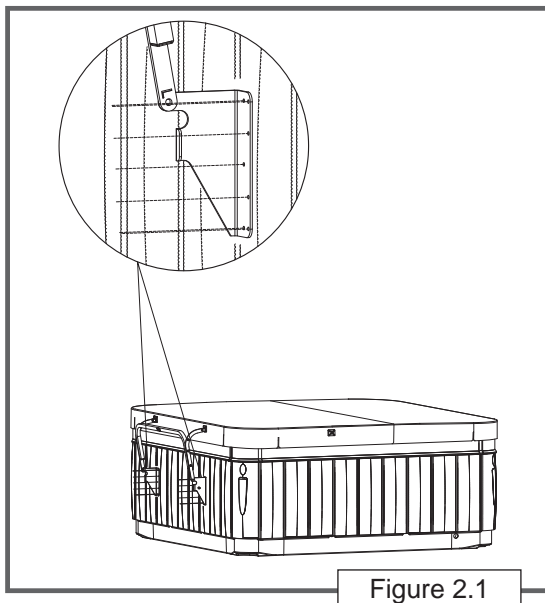

STEP 3

SECURE MOUNTING BRACKETS & SPACERS TO SPA

1. Making sure to align the holes on the bracket to the holes on the spacer (P1), secure the mounting bracket and spacers (P1) to the spa cabinet using (14) of the pan head screws (K) (Figure 1.3). Bag # 3 (K) (#10 2" Pan Head screws).

IMPORTANT: Make sure holes are facing towards the middle of the spa.

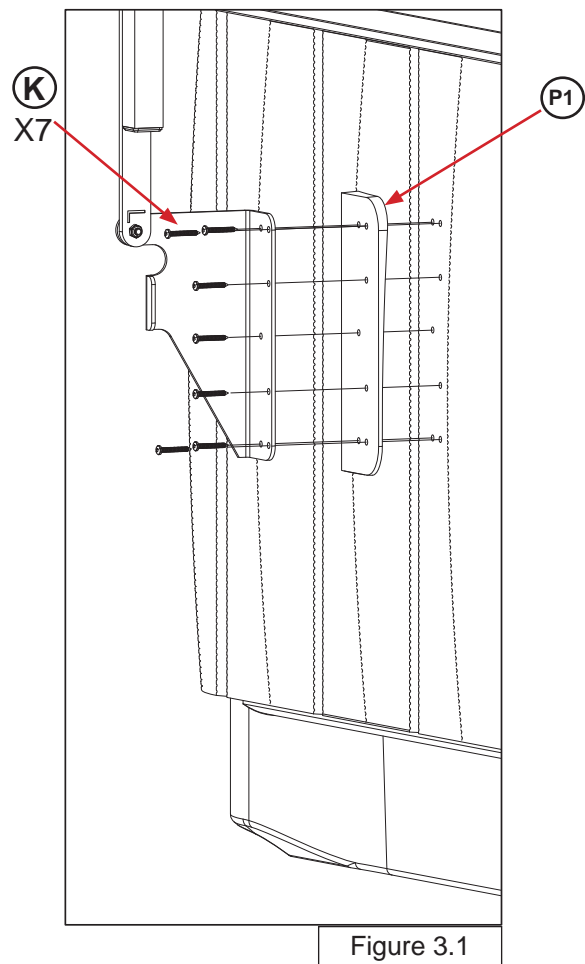

PIVOT BRACKET SPACER INSTALLATION

STEP 1 ALIGN SIDE ARM ASSY.

1. Locate the Template (H) and place on ground below Side Arm Assembly (Figure 4.1).

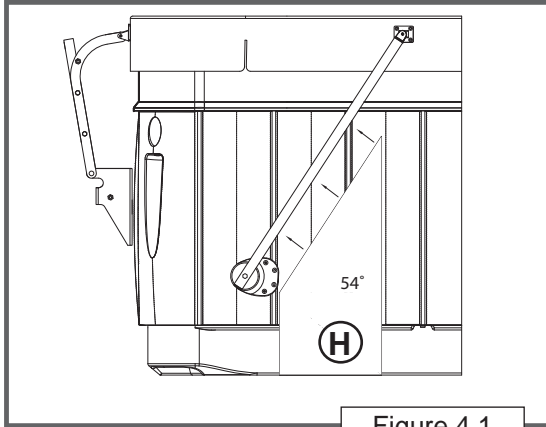

Figure 4.1

2. Slide Template against Side Arm Assembly making sure the entire angle of the Template touches the Side Arm Assembly (Figure 4.1)

STEP 2 DRILL HOLES INTO SPA

1. Position T1 or S1 Side Spacer against Pivot Bracket E, and insert two screws (L) from the back. Then position arm so rib of side spacer fits into appropriate groove, predrill 7/64" holes into the spa (Figure 5.1) with 1" max. depth. There are (4) holes per Pivot Bracket.
2. Position the Plastic Bottom (Pivot Bracket) (E) with the holes facing toward the middle of the spa (Figure 5.1).

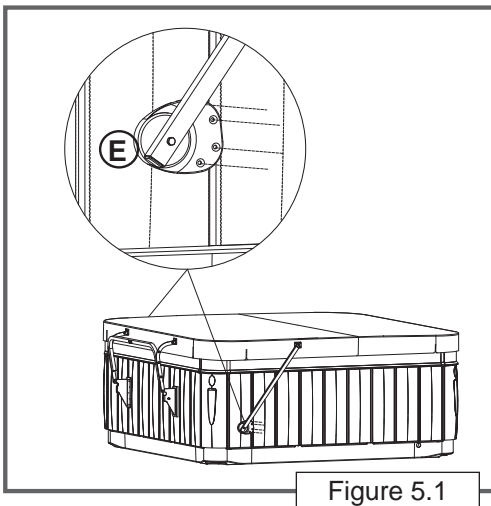

Figure 5.1

STEP 3 SECURE PIVOT BRACKETS & SPACERS TO SPA

1. Remove the two screws (L) from the back of T1 or S1. Making sure that the holes on Spacer (T1) align with Bracket (E), secure bracket and Spacer (T1) to spa using 4 Flat head Screws (L) (Figure 6.1). Bag # 3 (L) (#10 2" Flat Head screws).

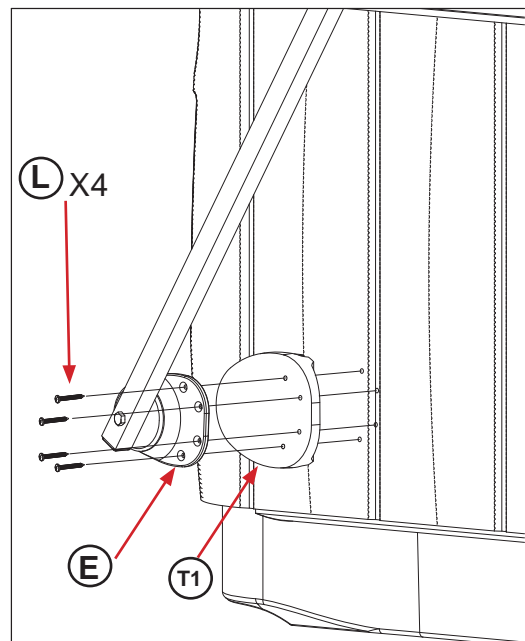

Figure 6.1

Important: Make sure that the Spacer (T1) back end fits into the vertical groove on side panel as shown(Figure 6.2).

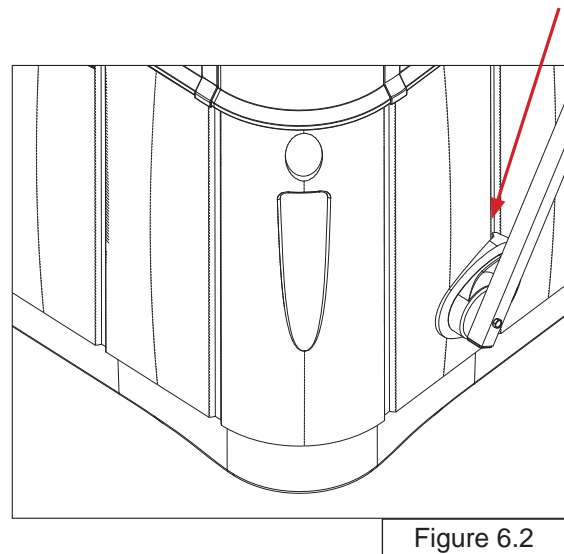

Figure 6.2



WatkinsWellness®

Feel good. Live well.™